



mirolxtec

water treatment

Cleaner Water for a Brighter Future®



GRIT COLLECTION SYSTEMS

www.mirolxtec.com



mirolxtec
water treatment

Cleaner Water for a Brighter Future®

GRIT COLLECTION SYSTEMS



Improve Plant
Performance with
Efficient Grit Removal

GRIT COLLECTION SYSTEMS

The purpose of the grit chamber is to remove grit before it can damage equipment or accumulate in channels or basins throughout the plant.

Two important factors to consider when determining if grit removal should be included in a plant design are the quantity and quality of the grit influx.

The quantity and quality vary because of different local characteristics:

separate or combined sewer system, type of soil, street conditions, climate, type of catch basins, maintenance of streets (sanding during inclement weather) and catch basins, type of sewers and their condition, the extensive use of kitchen grinders, and industrial wastes.

Grit includes sand, gravel, cinders, or other heavy solid materials that are "heavier" (higher specific gravity) than the organic biodegradable solids in the wastewater.

Grit also includes eggshells, bone chips, seeds, coffee grounds, and large organic particles, such as food waste.

Removal of grit prevents unnecessary abrasion and wear of mechanical equipment, grit deposition in pipelines and channels, and accumulation of grit in anaerobic digesters and aeration basins.

Grit removal facilities typically precede primary clarification, and follow screening and comminution. This prevents large solids from interfering with grit handling equipment.

*SpiraGrit™ Vortex
Grit Removal System*

*Aeroductor Aerated
Grit Removal System*

*In-Line Grit Collector
Grit Removal System*



Cleaner Water for a Brighter Future®



The average quantity of grit may vary from as little as 0.3 cu ft per million gallons of wastewater to as much as 14 cu ft per million gallons as reported by some wastewater treatment plants.

During peak flows, these quantities vary, from a low figure of 0.81 cu ft per million gallons to a high of 540 cu ft per million gallons.

Plants have reported maximum days with as high as 1,800 times the average daily grit capacity.

Therefore, while many plants have very little need for grit removal, others require a grit removal system.

Finally, the specific gravity and size of the grit particles are important design factors because of the obvious effect they have in separation and settling.

Primary Grit Collection Options

Lakeside offers a variety of primary grit removal systems including:

- SpiraGrit™ Vortex Grit Removal System
- Aeroductor Aerated Grit Removal System
- In-Line Grit Collector Grit Removal System

These primary grit removal systems can be designed by Lakeside to be installed in either concrete structures or pre-engineered fabricated carbon steel or stainless steel structures.

Secondary Grit Collection Systems Grit captured by the primary grit removal system is then pumped to either grit classification equipment or grit washing equipment including:

- Type “L” Grit Classifier
- Type “W” Grit Cyclone-Classifier
- Type RGC Grit Classifier
- *Raptor*® Grit Washer
- *Raptor*® Dry Grit Washer

Lakeside’s dedication to detail, state-of-the-art design features, operation simplicity, low maintenance requirements, and long life offer value-added grit removal to modern wastewater treatment facilities.



Type “L” Grit Classifier

Type RGC Grit Classifier

Raptor® Grit Washer



Type “W” Grit Cyclone-Classifier



SpiraGrit™ Vortex Grit Removal System

The SpiraGrit™ is a vortex grit removal system that relies on a mechanically induced vortex to capture grit solids in the center flat bottom hopper of a circular tank. The SpiraGrit™ operates efficiently over a wide range of daily flow rates. This is achieved by rotating paddles that maintain the flow velocity inside the grit chamber. The SpiraGrit™ is offered in sizes to handle peak flows ranging from 1.0 to 70.0 mgd.

Grit is removed from the storage hopper by an airlift pump, self-priming pump, or a dry-pit vortex pump, and piped to a Grit Classifier or *Raptor*® Grit Washer. Backwash from the Grit Classifier flows back to the grit tank. For the most efficient operation, the Grit Classifier or *Raptor*® Grit Washer should be positioned above the water level in the grit tank to permit backwash to return by gravity to the grit basin.

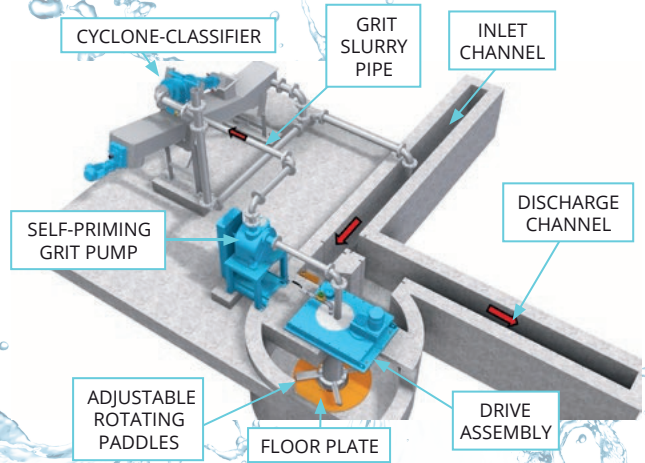

270-Degree SpiraGrit™



360-Degree SpiraGrit™



Tank Mounted SpiraGrit™

SpiraGrit™ features and benefits:

- **Compact design** available in either a 270-degree or 360-degree inlet/outlet configuration requires significantly less space
- **High removal efficiency** throughout the design flow range
- **Low headloss** through the unit, 1/4-inch maximum
- **Simultaneous grit separation and dewatering** for cleaner grit
- **No submerged bearing or parts** reduces maintenance
- **Optional all-stainless steel construction** for superior corrosion resistance.

Mirolxtec can provide the grit pumping system (airlift pump, self-priming pump, or dry-pit pump), Grit Classifier or *Raptor*® Grit Washer, and the electrical control panel.

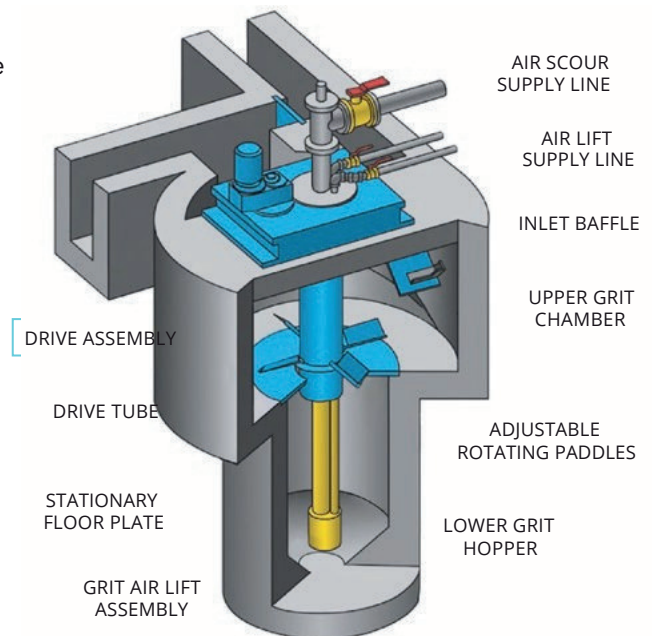

Aeroductor Grit Removal System

The Mirolxtec Aeroductor Grit Removal System provides a means to pre-aerate, remove, and dewater grit in a low energy system with no underwater moving parts. It is offered in sizes to handle peak flows ranging from 0.95 to 20.0 mgd.

The Aeroductor utilizes diffused air to circulate the liquid vertically and to control rotational velocity. The settled grit moves to the center of the hopper by both gravity and the scouring option of the moving liquid. A five (5) minute detention time at peak flow is used in sizing the tank. The grit removal efficiency is 95% of 65 mesh and larger grit having a specific gravity of 2.65 or greater.

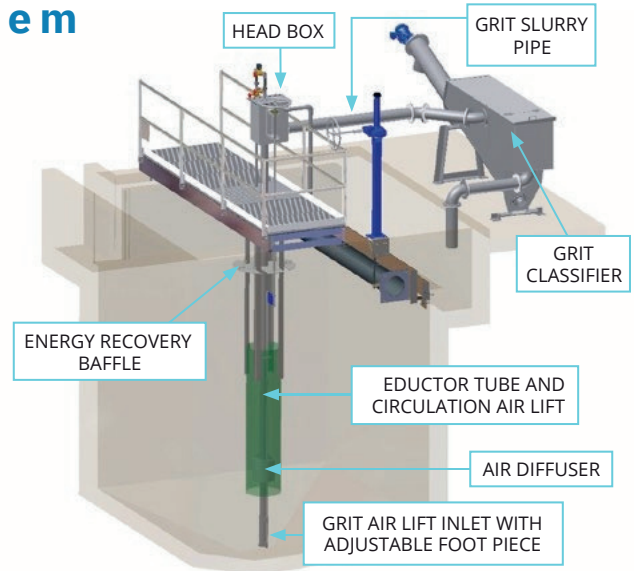

Aeroductor Grit Removal System

Circulation Air Lift

Aeroductor

Grit is removed from the storage hopper by an airlift pump, self-priming pump, or a dry-pit vortex pump, and piped to a Grit Classifier or *Raptor*® Grit Washer. Backwash from the Grit Classifier or *Raptor*® Grit Washer flows back to the grit tank. For the most efficient operation, the Grit Classifier or *Raptor*® Grit Washer should be positioned above the water level in the grit tank to permit backwash to return by gravity to the grit basin.

Aeroductor advantages:

- **Pre-aeration** to “freshen” incoming wastewater flow
- **Simultaneous grit separation and dewatering** for cleaner grit
- **Easy adjustment of circulation velocities** resulting in selectivity of grit quality
- **Steady performance** because flow variations have no influence on operation with a 5-minute minimum detention time at peak flow

- **Mixing control with simple air flow adjustments** to aid in keeping the organics in suspension while allowing the heavier grit to settle
- **Low energy requirement** to mix the tank
- **Low headloss** through the unit minimizes the system hydraulic profile
- **Less expensive straight wall design** is easier to form and pour than vortex system circular tanks
- **Reduced maintenance costs** since there are no chains, buckets or augers to wear
 - **Optional rotating scum skimmer** to remove floatable materials from the tank water surface
- **Optional all stainless steel construction** for superior corrosion resistance

Mirolxtec can provide the blower package, grit pumping system (airlift pump, self-priming pump, or dry-pit pump), Grit Classifier or *Raptor*® Grit Washer, and the electrical control panel.

In-Line Grit Collector

The In-Line Grit Collector provides a low-cost alternative for small treatment facilities. It is offered in sizes to handle peak flows ranging from 0.25 to 6.00 mgd. Its grit removal efficiency is 95% of 65 mesh and larger grit having a specific gravity of 2.65 or greater.

The In-Line Grit Collector consists of a baffled tank with air diffusers, effluent trough, and grit conveying and dewatering screw.

Wastewater flows in one end of the tank, under a baffle, up over an adjustable effluent weir trough, and out to the next unit in the treatment process minus the grit. The grit settles to the bottom of the tank where the grit dewatering screw conveys and dewateres the grit for discharge into a dumpster. The air diffusers maintain uniform circulation velocities for all flows to settle the heavier grit and to keep organic material in suspension.

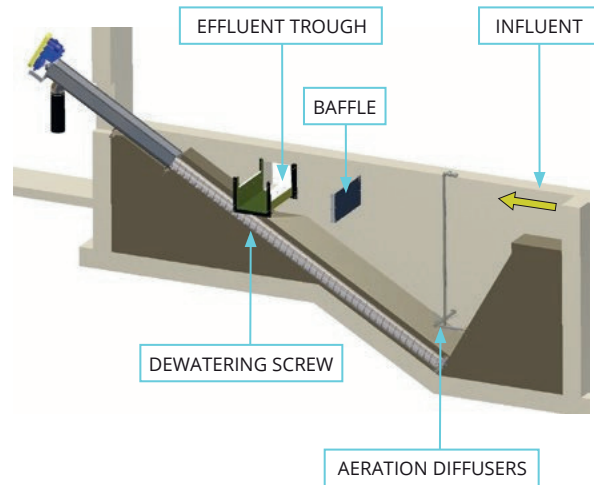

In-Line Grit Collector

Effluent Trough

Dewatering Screw



In-Line Grit Collector features and benefits:

- **Minimal mechanical equipment** reduces maintenance
- **No lengthy straight influent channels** required
- **No chains or buckets** to wear reduce maintenance costs
- **Simple tank construction** is easier and less expensive to form than circular tanks.
- **No intermediate hanger bearings** required for the grit dewatering screw
- **Screw conveyor wear** is eliminated due to grit (570 Brinell for silica sand) by a field-renewable continuous 1/2-inch wide Lincore 60-G hard weld (615 Brinell) that is applied to the outer leading face of the screw conveyor flights that only have a Brinell hardness of 120 (carbon steel) or 200 (stainless steel).
- **Direct drive speed reducer** with a NEMA C-face motor eliminates the cost and maintenance associated with V-belts and sheaves
- **Optional all stainless steel construction** for superior life and reduced maintenance

Mirolxtec can provide the blower package and the electrical control panel.

Cleaner Water for a Brighter Future®

Grit Classifiers are utilized to separate the captured grit from organics and water following the primary grit removal system such as the Miroxtec Aeroductor and SpiraGrit™. Grit Classifiers typically receive a grit slurry from an air lift pump, self-priming pump, or dry-pit vortex pump that is a 1 to 3% solids mixture.

The hopper of a traditional Grit Classifier is designed for the shortest retention time to allow heavier grit to settle, while the lighter organic material is carried out of the hopper via an overflow and returned to the flow ahead of the primary grit removal system.

Grit Classifiers are similar to a clarifier and are designed with a settling area based upon a peak hydraulic loading rate of 13.5 gallons per minute per square foot to remove 95% of 150 mesh (106 micron) and larger grit having a specific gravity of 2.65 or greater.

Grit that is settled in the classifier is removed and dewatered via a slow-moving screw conveyor.

The grit dewatering screw conveyors are available in sizes ranging from 9 to 24 inches. Grit dewatering screw conveyors are sized based upon Conveyor Equipment Manufacturers Association (CEMA) design parameters and are designed to convey grit based on a cubic feet per hour volume basis.

The screw conveyor conveys the grit out of the classifier settling area where it is dewatered and usually discharged into a dumpster to then be hauled to a landfill.

Miroxtec offers multiple Grit Classifier types which can be incorporated into your grit removal system.

Type "L" Grit Classifier

Large Capacity Model RGC Grit Classifier

Type "W" Grit Cyclone-Classifier



All Miroxtec Grit Classifiers provide the following advantages:

- **Direct-drive design** eliminates the cost and maintenance associated with drives that incorporate V-belts and sheaves as well as an upper thrust bearing for the screw conveyor.
- **Heavy-duty speed reducer** that is either a cycloidal-helical (in-line) or cycloidal-bevel (right-angle) design can absorb a 500% shock load without damage. The cycloidal-helical or cycloidal-bevel drives use a modern taper-grit bushing for easy installation and removal versus old-fashioned key and keyway design.
- **Abrasion-resistant continuous field-renewable hard weld** is provided for the screw conveyor flights that are either carbon steel (120 Brinell) or stainless steel (200 Brinell). The hard weld is 1/2-inch wide Lincore 60-G (615 Brinell) to resist abrasion from the grit (570 Brinell for silica sand).

- **External-mount lower screw conveyor bearing** built from state-of-the-art composite, self-lubricated non-metallic materials with dual seals and a stainless steel wear sleeve. The bearing housing is mounted external to the classifier tank for ease of access.
- **Optional supplemental washing system** is available to reduce the organics fraction in the dewatered grit. The system includes a spray nozzle, flow rate control valve, flow control solenoid valve, and plant water filter.
- **Optional all-stainless steel construction** provides superior corrosion resistance.

Miroxtec can provide the electrical control panel for the Grit Classifier and *Raptor*® Grit Washer.

Grit Classifiers

Type "L" Grit Classifiers Lakeside offers the following Type "L" Grit Classifiers:

Standard 30-Degree design that is rated for a peak grit slurry flow of 120 gal/min. A 9-inch grit dewatering screw is provided that can handle a peak grit conveying capacity of 18 to 30 cubic feet per hour depending upon the drive rotational speed.

Standard 20-Degree design that is rated for a peak grit slurry flow of 190 gal/min. A 9-inch grit dewatering screw is provided that can handle a peak grit conveying capacity of 18 to 30 cubic feet per hour depending upon the drive rotational speed.

Custom Models that can be designed for larger flows and grit conveying capacities.

Large Capacity Model RGC Grit Classifiers

Mirolxtec offers large capacity Model RGC Grit Classifiers in either a rectangular or circular tank design for grit slurry feed flow ranges of 400 to 800 gal/min. The Model RGC Grit Classifiers are custom-designed for the specific project.



Standard 20-Degree Type "L" Grit Classifier

Standard 30-Degree Type "L" Grit Classifier



Grit Classifiers

Type "W" Grit Cyclone-Classifier When receiving flows less than approximately 200 gal/min a cyclone is typically not necessary. Adding a cyclone to a Grit Classifier allows the settling area to be smaller to achieve the same retention time and grit capture efficiency. Cyclones separate the water from the grit, sending more than 90% of the feed flow back into the plant's process grit free. The grit slurry that is less than 10% of the feed flow is directed to the grit classifier settling area.

Grit slurry is introduced into the cyclone through a special involute design that pre-classifies material prior to entering the feed chamber. As the slurry enters the feed chamber, a centrifugal force is established and "spins" the grit to the wall of the cyclone forcing solids to discharge through the "underflow" apex orifice, along with some liquid. The remaining liquid and lighter particles are discharged through the overflow pipe.



Type "W" Grit Cyclone-Classifier

Type "W" Grit Cyclone-Classifier



Type "W" Grit Cyclone-Classifiers are available in different sizes depending upon the feed flow rate of the grit slurry and are selected based upon the inlet orifice cross sectional area and the size of the vortex finder. The cyclone is typically sized to provide a minimum 6 psig pressure drop (13.84 feet of water column), but not to exceed 10 psig (23.07 feet of water column). They come with field-replaceable liners that are neoprene rubber or a special abrasion resistant ceramic. Natural gum rubber liners can be degraded by fats-oils-greases (FOG) that is present in wastewater and are not recommended. Designs using multiple cyclones with a single Grit Classifier are also available.

The cyclone is oriented at an angle of 11.25 degrees as a standard, but can also be oriented at 22.5 degrees or 45 degrees that all match standard piping elbow configurations. ANSI 125/150 lb flanges or grooved piping connections are provided and the cyclone can be mounted to the classifier in either a standard or optional orientation.

The standard Type "W" Grit Cyclone-Classifier is rated for a peak grit slurry flow of 200 to 250 gal/min. A 12-inch grit dewatering screw oriented at 16 degrees from horizontal can handle a peak grit conveying capacity of 38 cubic feet per hour. Classifiers with larger cyclones, multiple cyclones, larger settling areas, and larger grit dewatering screws are also available.

RAPTOR® GRIT WASHERS

Raptor® Grit Washer The Raptor® Grit Washer is designed to provide superior grit classification and washing to any primary grit removal system. The organics are typically reduced to less than 10%. The Raptor® Grit Washer provides 98% removal of all grit 0.20 mm (74 mesh) and larger having a specific gravity of 2.65 or greater. The standard grit conveying screw capacity is 30 cu ft/hr.

Key features and design improvements of the Raptor® Grit Washer include:

- **All stainless steel construction**, all AISI Type 304 stainless steel provides superior corrosion resistance and long life of the unit. Optional all AISI Type 316 stainless steel construction is available.
- **Inlet chamber** imparts centrifugal force to the liquid and provides less headloss to the grit pump system head curve than competing units.
- **Circular settling chamber** provides optimum configuration for grit and organics separation.
- **Perimeter overflow weir** enables even flow collection unlike conventional rectangular grit classifiers. The organic laden overflow water is returned to the inlet of the primary grit chamber.
- **Cycloidal-helical drives** are included for the grit stirrer and grit dewatering screw to create a close-coupled design with an industry standard NEMA C-face motor that can be purchased from most any local motor shop.
- **Grit stirrer assembly** provides supplemental agitation and washing of settled grit in the settling chamber with a 1/2 hp drive.



Raptor® Grit Washer



Discharged grit is typically 90% dry weight or greater.
Organics are typically less than 10%.

- **Dual grit washing system** utilizes an external wash water source that operates on grit level for grit backwashing during continuous or intermittent operation of the unit. A second-stage grit washing system is provided in the grit dewatering screw near the air-liquid interface.
- **Organics blow down valve** is included to OPEN when the grit bed is backwashed. The organics blowdown valve is a water-actuated pinch valve with a 3-way solenoid for superior reliability. The organic laden water is returned to the inlet of the primary grit chamber.
- **Heavy-duty grit dewatering screw** that conveys washed grit out of the unit and dewateres the grit is completely fabricated of stainless steel for corrosion resistance. The grit dewatering screw is provided with a 1.5 hp drive assembly. The flights of the screw are provided with a field-renewable 1/2-inch wide continuous Lincore 60-G (615 Brinell) hard weld.
- **Grit dewatering screw self-lubricated lower bearing** is non-metallic and corrosion resistant GarMax sleeve bearing. Dual seals with a stainless steel wear sleeve prevent grit from entering the bearing housing. The bearing housing is a bolted design that allows for easy bearing and seal replacement without disassembly.

The *Raptor*® Grit Washer is available in four (4) different models:

- Model 150RGW (150 gal/min)
- Model 250RGW (250 gal/min)
- Model 400RGW (400 gal/min)
- Model 500RGW (500 gal/min)

Dry *Raptor*® Grit Washer The *Raptor*® Dry Grit Washer is designed to provide superior grit classification and washing to any grit that has been dewatered via a standard grit classifier. The organics are typically reduced to less than 10%. The *Raptor*® Grit Washer provides 98% removal of all grit 0.20 mm (74 mesh) and larger having a specific gravity of 2.65 or greater. The standard grit conveying screw capacity is 30 cu ft/hr.

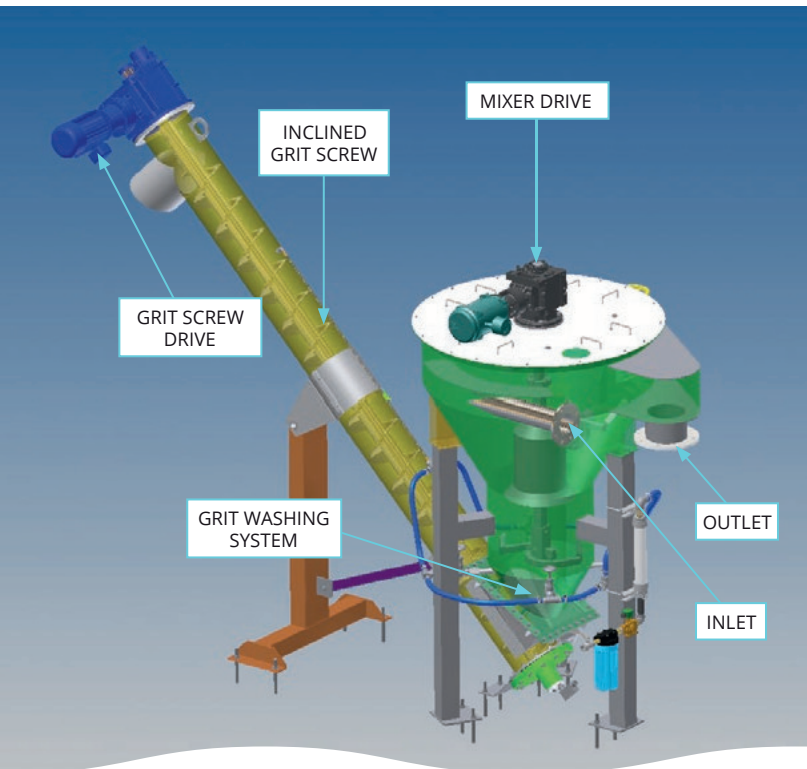

Raptor® Grit Washer



Raptor® Dry Grit Washer

Classified grit is introduced into the *Raptor*® Dry Grit Washer from a standard grit classifier, a grit conveying system (screw or belt), or can be provided with a cyclone to receive pumped grit slurry from the primary grit removal unit. Organics are then separated from the sand particles via the introduction of upwardly directed wash water. Settled grit in the lower part of the *Raptor*® Dry Grit Washer will be fluidized to expand the grit bed where the lighter organic particles are separated from the dense grit particles, independent of the particle size. This process is supported by the central grit stirrer assembly that keeps the particles in motion.

After removal of the organic material the clean grit is removed via a grit dewatering screw, statically dewatered, and discharged into a dumpster. The removed organics are automatically recycled back to the process.

The *Raptor*® Dry Grit Washer offers the same benefits as the standard *Raptor*® Grit Washer.

Treatment equipment and process solutions from Mirolxtec Equipment Corporation

Mirolxtec offers a wide range of equipment and systems for virtually all stages of wastewater treatment from influent through final discharge. Each process and equipment item that we supply is manufactured with one goal: to reliably improve the quality of our water resources in the most cost-effective way. We have been doing just that since 1928.

Screw Pumps

Open Screw Pumps
Enclosed Screw Pumps
Raptor® Screening

Fine Screen
Micro Strainer
Rotating Drum Screen
Septage Acceptance Plant
Septage Complete Plant
Complete Plant
Multi-Rake Bar Screen
FalconRake® Bar Screen
Rotary Strainer Screen
Wash Press

Screen and Trash Rakes

Hydronic T Series
Hydronic K Series
Hydronic Multifunctional Series
Hydronic H Series
Catronic Series
Monorail Series
HY-TEC
Screen CO-

ROTEC Screen

Grit Collection

SpiraGrit™ Vortex Grit Removal System
Aeroductor Grit Removal System
In-Line Grit Collector
Raptor® Grit Washer
Grit Classifier

H-PAC®

Clarification and Filtration

Spiraflo Clarifier
Spiravac Clarifier
Full Surface Skimming

Biological Treatment

CLR Process
Magna Rotor Aerators & Accessories
Sequencing Batch Reactors
Package Treatment Plants
Submersible Mixers & Recirculation Pumps
Hauled Waste Receiving Systems

Raptor® Septage Acceptance Plant
Raptor® Septage Complete Plant
Raptor® FOG Acceptance Plant
Package Headworks Systems
Raptor® Complete Plant

H-PAC®

Biological Treatment Systems

CLR Process
Package Treatment Plants
Sequencing Batch Reactors
SharpBNR™ Process Control



mirolxtec
water treatment

Phone : +32474050255

Email : info@mirolxtec.com

Address : Generaal Lemanstraat 55/2 2019 Antwerpen Belgium

www.mirolxtec.com