



mirolxtec
water treatment

SCREW PUMPS



www.mirolxtec.com



Mirolxtec SCREW PUMPS



Flexibility. Proven Design.
Trouble-Free Operation.



Proven Design and Decades of Experience

Since 1928, engineers and owners have relied on Miroxtec's engineering expertise in the design and manufacturing of state-of-the-art process equipment. For more than 50 years, Miroxtec Screw Pumps have provided proven design, trouble-free operation, and flexibility of both Open and Enclosed designs with more than 2,000 units that are completely manufactured in the Belgium at our state-of-the art fabrication facility. Miroxtec Screw Pumps are an efficient means of lifting large quantities of wastewater or water at a low static head.

Miroxtec's Screw Pumps, which are patterned after the Archimedean screw, consist of a tube with spiral flights set in an inclined trough. The entire assembly consists of the spiral screw, an upper bearing, a lower bearing, and a drive assembly. Each of these elements is simple and basic in design.

Miroxtec is the only Belgium manufacturer that consistently offers all three (3) types of screw pumps:

- 1) Open Screw Pump
- 2) Type "S" Enclosed Screw Pump
- 3) Type "C" Enclosed Screw Pump

Open Screw Pump – Single Stage Design



Open Screw Pump – Dual Stage Design



Open Screw Pumps

Open Screw Pumps are normally placed into a concrete or fabricated steel, semicircular open trough. The trough can be constructed at a minimum angle of inclination of 22° up to a maximum angle of 40°. The standard angles of inclination are 30° and 38°. Open Screw Pumps are available in sizes ranging from 12-inch to 144-inch diameter with one, two, or three helical flights. Open Screw Pumps are designed to pump from as low as 90 gal/min to more than 55,000 gal/min at a hydraulic lift (H1) up to 50 feet in a single stage. Dual stage designs are available to meet higher lifts. Open Screw Pumps are up to 75% efficient. The pump is supported by an upper bearing that is engineered to handle the design thrust and radial loads of the pump and a lower bearing that is engineered to handle the design radial load only.



Type “S” Enclosed Screw Pumps Type “S”

Enclosed Screw Pumps utilize the same design and operating principles as Open Screw Pumps, but are enclosed in stationary steel tube rather than in an open trough. Type “S” Enclosed Screw Pumps are available in sizes ranging from 12-inch to 60-inch diameter with one, two, or three helical flights and can be constructed at angles ranging from 22° to 40°. Type “S” Enclosed Pumps are designed to pump from as low as 90 gal/min to more than 10,000 gal/min at a hydraulic lift (H1) up to 30 feet in a single stage. Type “S” Enclosed Screw Pumps are up to 75% efficient. Dual stage designs are available to meet higher lifts and can be designed to pivot at different operating angles to adjust the pumping rate. The Type “S” Enclosed Screw Pump is supported by the same upper bearing and lower bearing designs as our Open Screw Pumps.

Type “S” Enclosed Screw Pump



Type “C” Enclosed Screw Pumps

Type “C” Enclosed Screw Pumps are designed with two convoluted flights that are welded to the inside of a rotating steel tube. Type “C” Enclosed Screw Pumps are available in sizes ranging from 24-inch to 120-inch diameter. Type “C” Enclosed Pumps are designed to pump from as low as 540 gal/min to more than 35,000 gal/min at a hydraulic lift (H1) up to 60 feet in a single stage. Dual stage designs are available to meet higher lifts. Type “C” Enclosed Screw Pumps are up to 86% efficient. The pump is supported by an upper bearing that is engineered to handle the design thrust and radial loads of the pump and lower rollers that support the rotating pump body on a forged steel ring that is attached to the rotating pump body. The lower rollers and the forged ring are located above the fluid that is being pumped. Type “C” Enclosed Screw Pumps are designed to operate at 38° or 45°.

Type “C” Enclosed Screw Pump



Type “C” Enclosed Screw Pump



Screw Pump Selection

Mirolxtec’s three styles of screw pumps and individual advantages of each type allow the selection of the most appropriate design based upon specific application factors. Lakeside engineers are ready and available to discuss advantages, pros and cons of open or enclosed screw pumps, as well as make recommendations to best suit your specific requirements.

Screw Pump Applications

Since the third century B.C., the Archimedes screw pump has been used for irrigation and land drainage. Modern screw pumps have a variety of applications such as:

- Influent wastewater treatment plant lift stations
- Intermediate wastewater treatment plant lift stations
- Return activated sludge (RAS)
- Storm water pumping
- Effluent pumping
- Industrial applications
- Irrigation projects
- Drainage projects
- Reclamation of wetlands
- Amusement park water rides
- Fish-friendly pumping stations

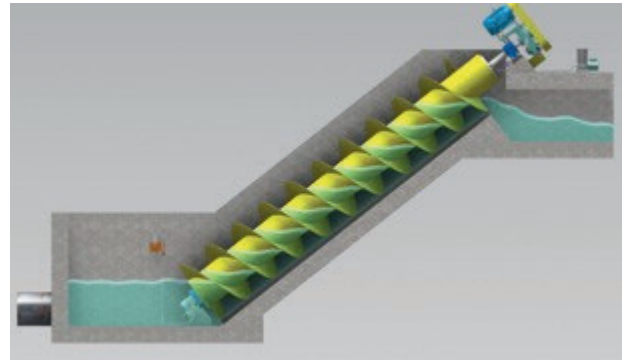

Wastewater treatment plant lift stations

Because screw pumps are non-clogging, they offer high reliability and handle most objects in raw wastewater influent. Since screw pumps require so little attention, they are extremely well suited for remote lift stations.

Return activated sludge

Screw pumps are excellent for pumping return sludge from the clarifier back to the aeration basin in activated sludge treatment. The gentle lift reduces break up of fragile activated sludge floc particles.

Storm water pumping

Screw pumps are ideally suited for widely ranging storm flows because of the large capacity. They can take discharge from storm drains or act as standby units to bypass storm flows.

Industrial Screw pumps can be used for pumping chemicals or other process liquids where low shear requirements and the prevention of emulsification are important.

Irrigation and drainage

For hundreds of years, screw pumps have been used for flood control. They are particularly useful for pumping large volumes of water at a low head.

Amusement park water rides

Screw pumps are well-suited for providing large volumes of water for water park rides for low lift applications.

Fish-friendly pumping stations

Screw pumps offer an ideal design to elevate fish in rivers and streams to assist in their migration around dams. The low rotational speed, large space between the flights, special flight profile at the intake of the pump body, and lower envelope ensure a fish-friendly design.

Lakeside Screw Pump Advantages

Mirolxtec screw pumps offer many advantages over other types of pumps. Specifically, screw pumps offer variable pumping capacity while operating at a constant speed, provide high pumping efficiency over a wide operating range, handle large objects without clogging, and require minimum maintenance:

- **Variable capacity reduces initial costs** - The built-in variable capacity of a screw pump automatically adjusts the pumping rate and power consumption to the depth of liquid in the inlet chamber while operating at a constant speed. The variable capacity saves money on initial cost by eliminating the need for elaborate variable speed electrical controls. The pumping rate is a function of the fill depth in the wet well.
- **High efficiency pumping lowers cost of electric power** - Screw pumps provide 70% to 75% efficiency from 30% to 100% of the rated pump capacity. The high-efficiency pumping results in lower electrical costs over the entire life of the equipment.
- **Screw pumps handle large objects so pumps won't clog** - Screw pumps require no pre-screening or grinding of solids and pass any debris as large as the gap between screw flights. The screw pump will not clog because it rejects large objects.

- **Minimal maintenance and upkeep requirements** - Slow operating speeds reduce friction that damages parts and causes heat generation. Only periodic maintenance is required for drive speed reducer oil changes and grease-lubrication of the upper and lower bearings.

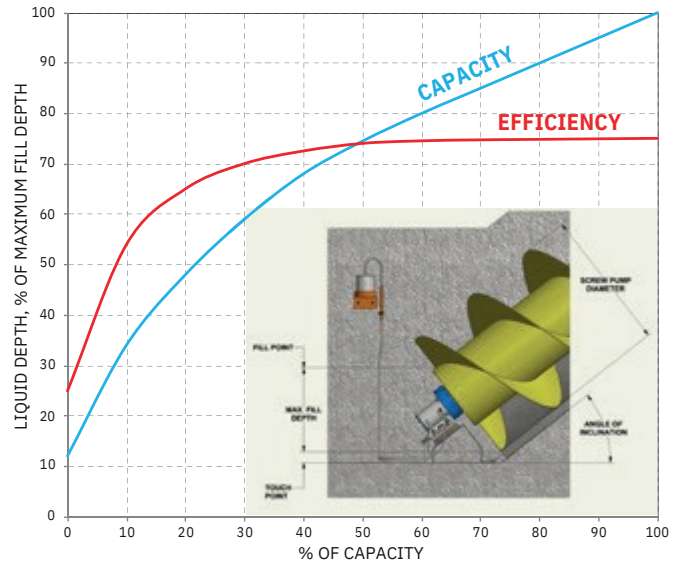

Mirolxtec Screw Pumps Versus Centrifugal Pumps Screw pumps do not require a deep wet well, pump house, or suction and discharge piping-fittings-valves. The screw pump can fit into a channel that is only slightly lower in elevation than the influent pipe or channel. The shallow wet well eliminates frequent on and off pump operation.

Screw pumps are a positive displacement device that only require a design to meet static pumping head (**H1**) requirements. Centrifugal pump designs must overcome the static head (**H1**) requirements, plus wet well level variation (**H2**) requirements for constant speed designs, and friction losses (**H₃**) in suction and discharge piping, fittings, and valves that results in a greater required total dynamic head (TDH) than screw pumps. The greater TDH that is required for centrifugal pumps will increase life cycle energy costs and may require a larger pump motor.

Centrifugal pumps normally require a deeper wet well, pre-screening or grinding to prevent pump plugging due to large debris, and sophisticated controls (e.g. variable frequency drives) that increase the initial overall installation costs.

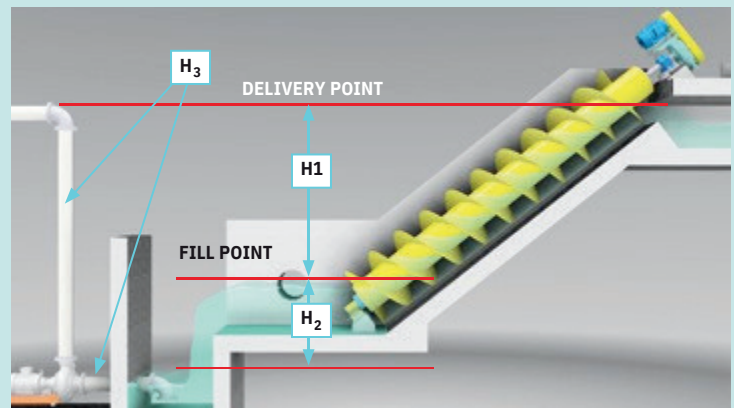

Proven Mechanical Design and Simple Operation

Three types of Miroxtec screw pumps consist of four basic elements: screw body, upper and lower bearings, drive assembly, and conveyance trough or tube. Each element incorporates design features that result in years of trouble-free operation.

Open Screw Pump Body The spiral screw consists of a torque tube with a minimum wall thickness of 3/8-inch with increased wall thickness to provide higher lift requirements. The helical-shaped flights are die-formed and are continuously welded on both sides of the tube. All butt welds between flight sections are full penetration welds in accordance with ANSI/AWS D1.1 "Structural Welding Code Steel" published by the Belgian Welding Society for structural integrity. For pumps up to 84-inch diameter there is only one radial weld per pitch and for pumps greater than 84-inch diameter there are only two radial welds per pitch to minimize welding and to ensure an even flight profile.

Flight thickness varies with screw diameter. Normal flight thickness requirements are 3/16-inch thick for 12-inch through 24-inch, 1/4-inch thick for 30-inch through 72-inch, and 5/16-inch thick for pumps 80-inch and greater in diameter. Flights should be continuously welded on both sides of the flights to the center tube. Flight butt welds are ground flat on the leading face of the flights to reduce paint wear by grit and sand. The screw is machined after fabrication to ensure that the pump flights are within Lakeside's stringent tolerances and that the pump body is dynamically balanced. To ensure true alignment of the upper and lower stub shafts, the end plates are machined after all of the welding is complete on the entire screw.

Open Screw Pumps



Open Screw Pump Flights

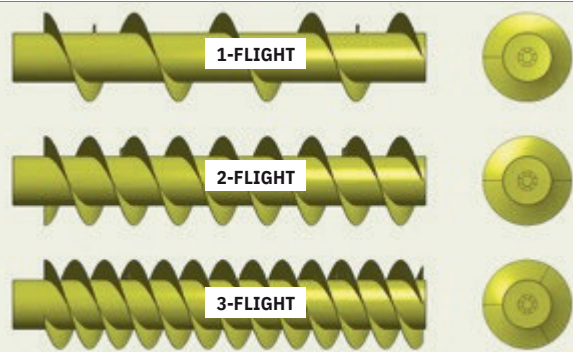

The typical Open Screw Pump body material of construction is carbon steel. Customized designs are available in all stainless steel fabrication and a combination of a carbon steel torque tube with stainless steel flights.

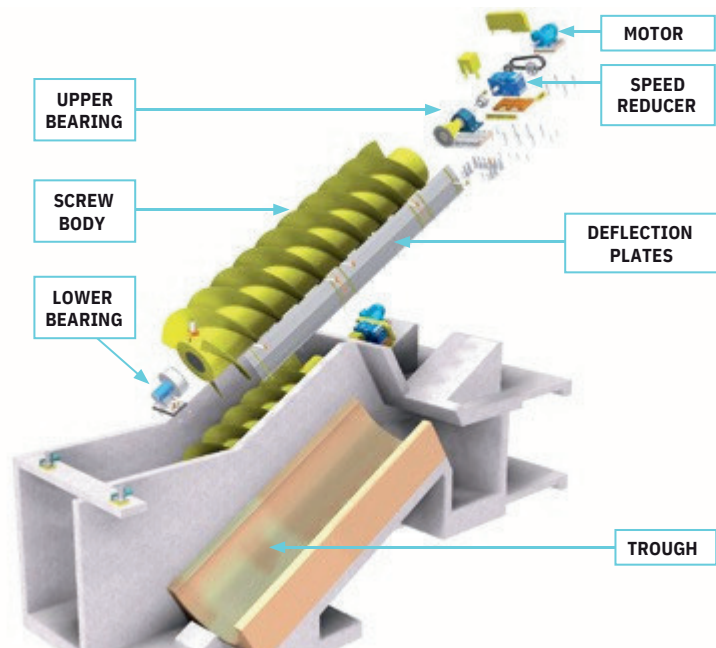

Type "S" Enclosed Screw Pump Body

Type "S" Enclosed Screw Pumps are an Open Screw Pump operating in an outer stationary tube. The upper bearing, lower bearing options, and drive assembly options are identical as for Open Screw Pumps.

The top of the stationary tube may be fixed or mounted on a pivot joint to allow raising the lower end out of the pit for repair. The pivot design also may be used to vary flow rate by changing the angle of inclination of the pump. The Type "S" Enclosed Screw Pumps provide a means for installing a screw pump assembly in existing tankage with a minimum of structural concrete work. Vents are provided in the stationary tube to allow air to enter and exit.

The typical Type "S" Enclosed Screw Pump body and outer tube material of construction is carbon steel. Customized designs are available in all stainless steel

fabrication and a combination of a carbon steel torque tube with stainless steel flights. Carbon steel Type "S" Enclosed Screw Pumps are typically factory finish coated prior to shipment.

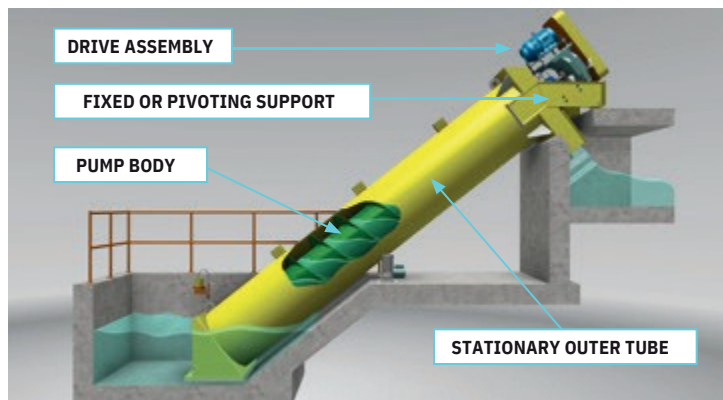

Type "S" Enclosed Screw Pumps



The Lakeside Type "S" Enclosed Screw Pumps provide a significant cost-saving option for the owner when replacing our competition's Type "C" Enclosed Screw Pumps at 38-degrees.



COMPETITOR TYPE "C" ENCLOSED SCREW PUMP

LAKESIDE TYPE "S" ENCLOSED SCREW PUMP

Type “C” Enclosed Screw Pump Body

The pump body of a Type “C” Enclosed Screw Pump consists of two convoluted flights that are continuously welded to the rotating outer tube. The upper structural drive support tube is extended into the pump body and welded to the dual convoluted flights. The drive support tube with pump body is bolted to the upper drive stub shaft flange and connected into the upper bearing assembly.

A lower bearing forged support ring is bolted to the outer rotating tube and is located approximately 1/3 of the pump body length from the lower end. The lower support of the Type “C” Enclosed Screw Pump is provided by a set of rollers that are located above the maximum water level of the lower pump wet well.

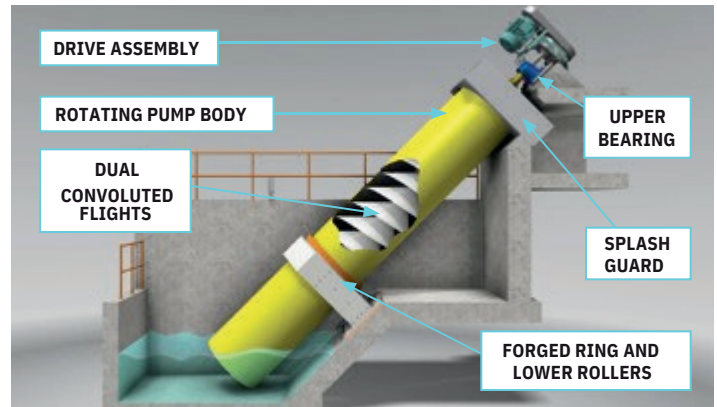

Type “C” Enclosed Screw Pump Body

All Stainless Steel

Stainless Steel – Aluminum
Bearing Cover

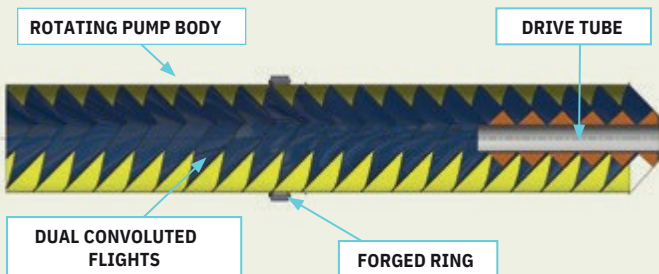

Compared to competing designs, the Lakeside Type “C” Enclosed Screw Pump is engineered to provide lower operating stresses that extend the operating life by using greater materials sizes and thicknesses including:

- Rotating outer tube with a greater wall thickness
- A larger diameter structural drive support tube
- A structural drive support tube with a greater wall thickness
- A structural drive support tube that extends a greater distance into the pump body

The typical Type “C” Enclosed Screw Pump body and splash guard material of construction is carbon steel. Customized designs are available to provide all stainless steel fabrication. To reduce the weight and to provide greater corrosion resistance, the lower forged ring and roller cover guard can be fabricated of lightweight aluminum.

Upper Bearing Assembly Open and enclosed screw pumps utilize the same state-of-the-art upper bearing design. The cast iron housing is split to allow easy internal inspection and access to the bearings without having to disconnect it from the drive assembly and remove it from the upper drive stub shaft. Spherical roller bearings are provided so that each performs a specific function. The first dual spherical roller bearing carries one-half of the operating radial load of the pump. The second bearing carries all of the operating thrust load of the pump. The bearings are sized for the maximum allowable pumping capacity of the pump and provide a minimum AFBMA L-10 theoretical design life of 100,000 hours.

Unlike competing designs that use a locknut that can seize or gall to secure the bearing, the Mirolxtec upper stub shaft is held into the bearing housing by a unique split collar and locking halter design. The split bearing housing allows easy internal inspection and access to the bearings by removing four bolts. The upper bearings are manually grease-lubricated via dedicated Zerk fittings.

The dual spherical radial bearing and the spherical thrust bearing are accurately positioned in the bearing housing to provide three dimensional (3D) alignment of the bearing pressure centers with the centerline of the upper stub shaft. This design ensures that the pump is self-aligning in all three axes (3D) with respect to the upper bearing as dynamic pumping loads vary.

Upper Bearing Assembly

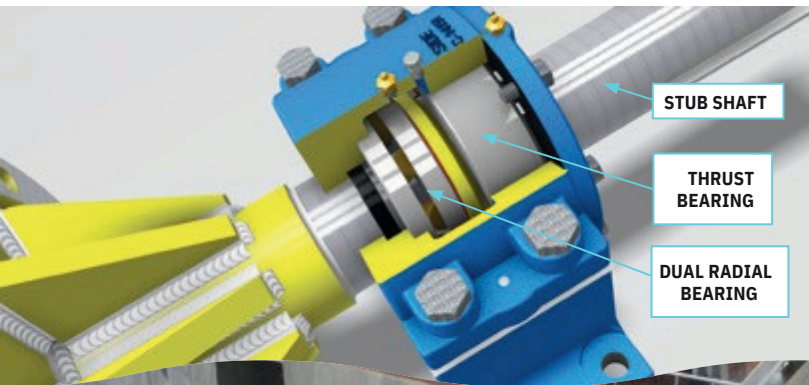

Upper Bearing Pressure Centers

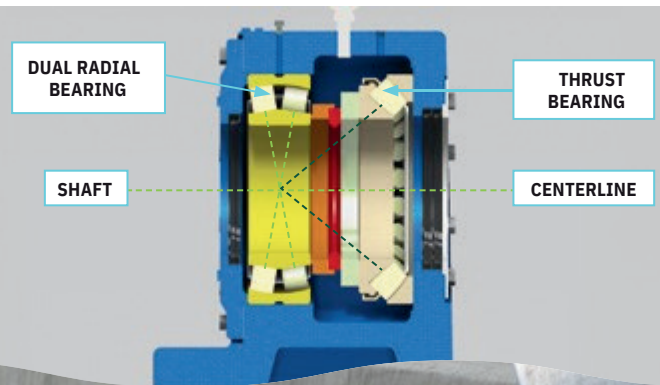

Open Screw Pumps and Type “S” Enclosed Screw Pumps Lower Bearing Assembly Lakeside offers two lower bearing types including a heavy-duty bronze bushing design, and a sealed precision Type “E” bearing design.

Heavy-Duty Design

The heavy-duty lower bearing utilizes a unique bronze sleeve bearing on a rocker (cam) base assembly that is automatically and continuously greased when the pump operates. The bearing design provides 3D alignment of the bearing with the centerline of the lower stub shaft. The bearing automatically compensates for expansion and contraction due to temperature fluctuations, maintains alignment as pump deflection changes, and ensures uniform distribution of one-half of the operating radial load.

Competing designs press the bronze bushing into the bearing housing and the lower stub shaft rotates on the inside diameter (I.D.) of the bushing that causes wear only on the lower portion of the fixed bronze bushing bearing. The mirolxtec heavy-duty bronze bushing is pressed onto the rotating lower stub shaft. This unique design feature distributes the radial load evenly on the outside diameter (O.D.) of the bearing, which effectively reduces the bearing load and provides for even wear over the entire circumference of the bronze bushing bearing.

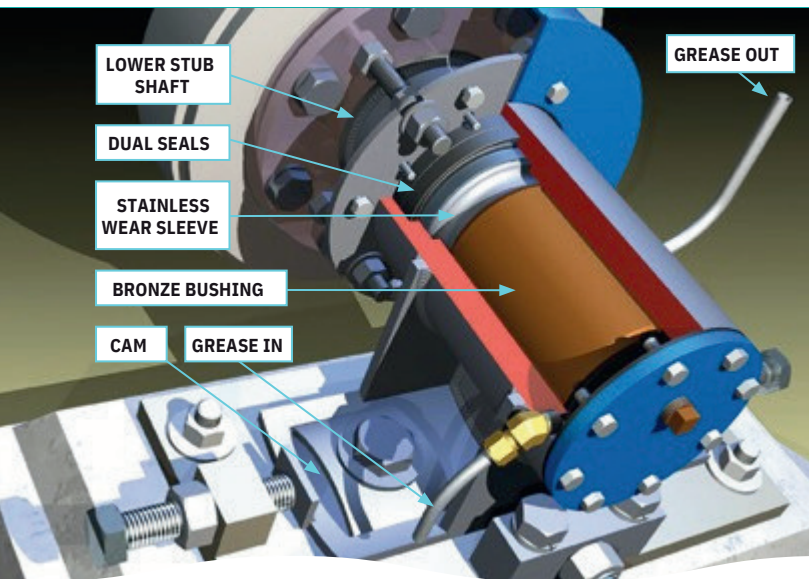

Lower Bearing Assembly

Grease grooves are designed into the bronze bushing bearing to evenly distribute the lubricating grease over the entire bearing surface. Dual back-to-back seals are provided, one to maintain grease within the bearing housing and one to keep the pumped fluid out of the bearing housing. A field-replaceable stainless steel wear sleeve is provided on the rotating lower stub shaft as a surface for the dual seals to ride on.

A positive-displacement grease pump is electrically interlocked using a centrifugal switch in the grease pump motor with the operation of the screw pump to supply a constant low-volume supply of grease to the lower bearing. The standard grease reservoir is stainless steel.

Reservoir with Low Level Switch



Spent Grease Recovery

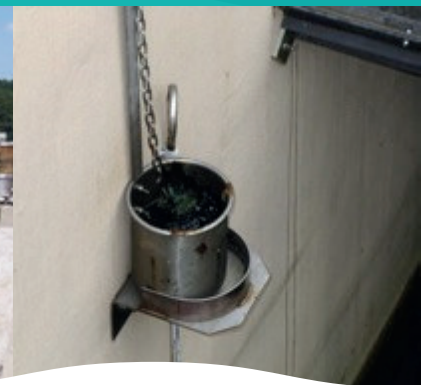

An optional low-level grease reservoir switch can be supplied to provide a signal to the plant controls system that the reservoir needs to be filled with lubricant. This optional feature requires that the grease reservoir be fabricated of FRP.

The spent grease is directed from the lower bearing up into a stainless steel grease collection container. This feature prohibits environmental contamination and allows for proper disposal of the spent grease. The grease recovery system also provides a positive visual confirmation that the lower bearing assembly is being properly lubricated or provides an indication that the lower dual seals require replacement.

Sealed Precision Type “E” Design The Sealed Precision Type “E” bearing assembly incorporates a sealed, grease-lubricated, specially- designed spherical roller bearing that requires minimal maintenance during the life of the bearing. This bearing eliminates the requirement for a lower bearing grease pump. The bearing design provides 3D alignment of the bearing with the centerline of the lower stub shaft. The optional sealed precision Type “E” bearing assembly is designed for continuous or intermittent operation in submerged or non-submerged conditions and is self-aligning to handle screw pump body deflection and thermal expansion.

The optional sealed precision Type "E" bearing assembly offers the following advantages:

- Minimal maintenance for lifetime of the roller bearing
- No grease pump or grease lines
- Environmentally friendly – grease is contained in bearing housing

Lakeside’s sealed precision Type “E” bearing assembly can be re-lubricated without having to remove the bearing from the pump. We use a larger bearing element with a longer AFBMA L-10 theoretical design life than competing manufacturers. The re-lubrication schedule is based upon three factors: bearing size, radial loading, and operating time. Re-lubrications requires only 1 to 6 ounces of grease every 10,000 to 30,000 of operation depending upon bearing size.

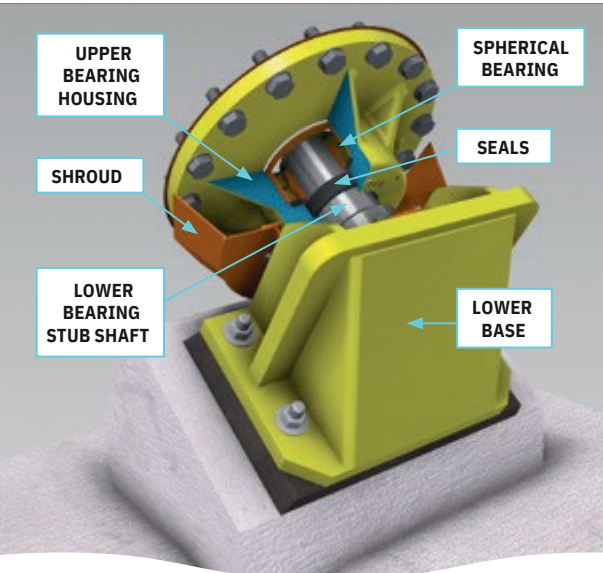

Sealed Type "E" Lower Bearing Assembly

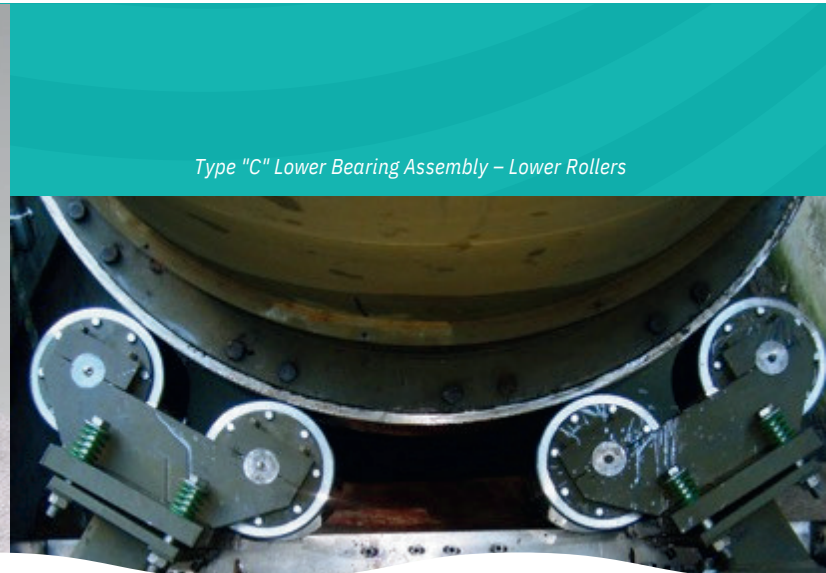

Type "C" Lower Bearing Assembly – Lower Rollers

Type “C” Enclosed Screw Pumps Lower Bearing Assembly

The Type “C” Enclosed Screw Pump lower bearing assembly consists of rollers that support a forged, hardened ring that is mounted on the outer rotating tube. To provide for expansion, contraction, and variation in deflection, two sets of rollers are mounted in a cradle which is supported on a self-aligning bearing. This arrangement carries the radial load of the pump and provides positive tracking of the rollers at all times. The roller and forged ring geometry and Brinell hardness have been designed by Mirolxtec engineers to provide a long life.

Lubrication for the rollers and forged ring is provided by two methods: drip oiler assembly, or pump oiler assembly. Lubricant is evenly spread on the forged ring by a brush assembly.



Drip Oiler



Pump Oiler

Drive Assemblies

Mirolxtec offers a variety of drive configurations for our screw pumps including shaft-mounted drives and multiple base-mounted drive designs.

Shaft-Mount Drives

Shaft-mounted drive designs are typically used up to 60 horsepower. The shaft-mounted drive is an economical design that offers simplicity consisting of a shaft-mounted speed reducer with hollow bore that connects to the upper screw pump stub shaft, torque-arm bracket to stabilize the reducer, V-belt and sheaves with belt guard, motor mount, and top-mounted motor.

Shaft-Mounted Drive Assembly

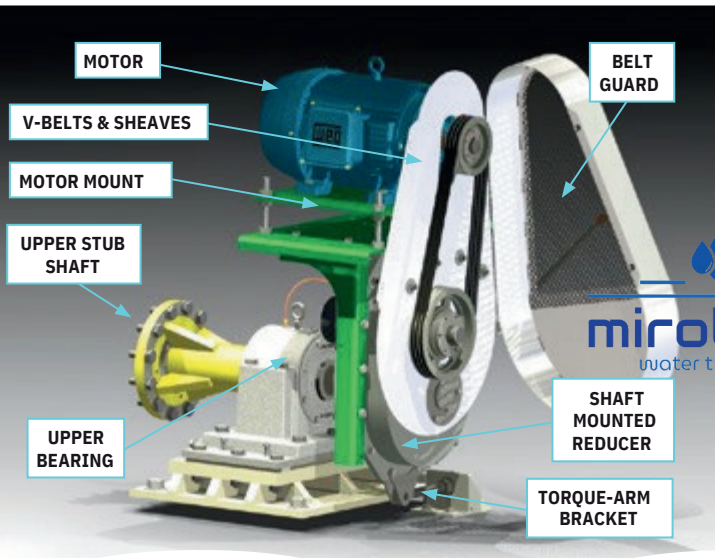

Shaft-Mounted Drive Assembly



Base-Mount Drives

Base-mounted drives are typically utilized for applications that require 75 horsepower and larger motors. Base-mounted drives are available in concentric shaft, parallel-shaft, or right-angle configurations.

- **Concentric Design** – Concentric base-mounted

drive designs are typically used up to 125 horsepower. The concentric base-mounted drive is an economical design that offers simplicity consisting of a concentric base-mounted speed reducer that connects to the upper screw pump stub shaft via a low-speed coupling, V-belt and sheaves with belt guard, motor mount, and top-mounted motor.

Concentric Drive Assembly

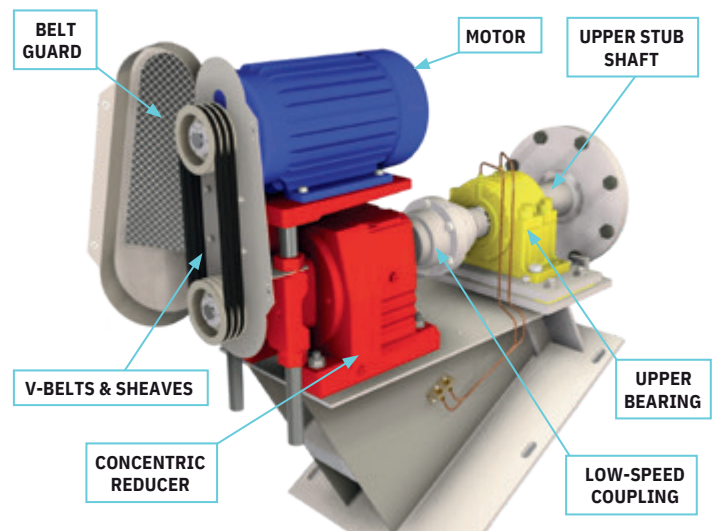

Concentric Drive Assembly

- Parallel-Shaft Design** – Parallel-shaft base-mounted drive designs are typically utilized for applications that require 100 horsepower and larger motors. It consists of a parallel-shaft base-mounted speed reducer that connects to the upper screw pump stub shaft via a low-speed coupling, V-belt and sheaves with belt guard, motor mount, and base-mounted motor.

- Right-Angle Design** – Right-angle base-mounted drive designs are typically used for 100 horsepower and larger. It places the motor at a more convenient location for maintenance and consists of a right-angle base-mounted speed reducer that connects to the upper screw pump stub shaft via a low-speed coupling, V-belt and sheaves with belt guard, motor mount, and base-mounted motor.

Parallel-Shaft Drive Assembly

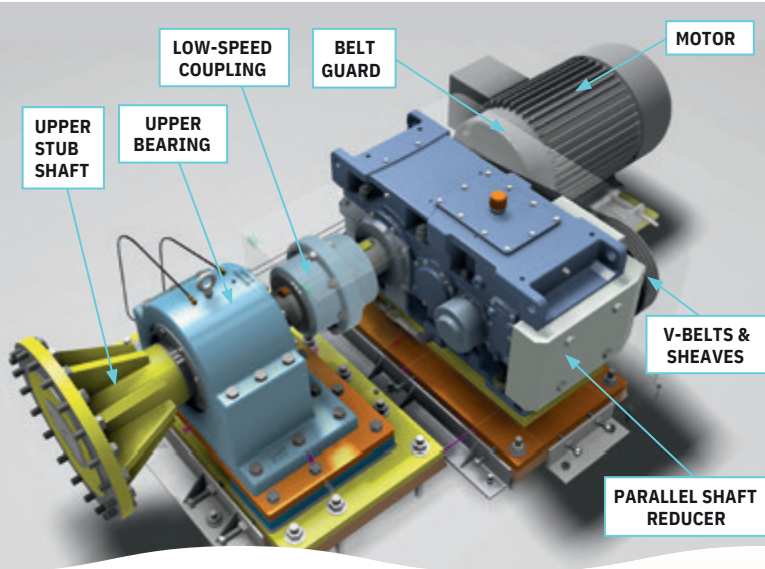

Right-Angle Drive Assembly

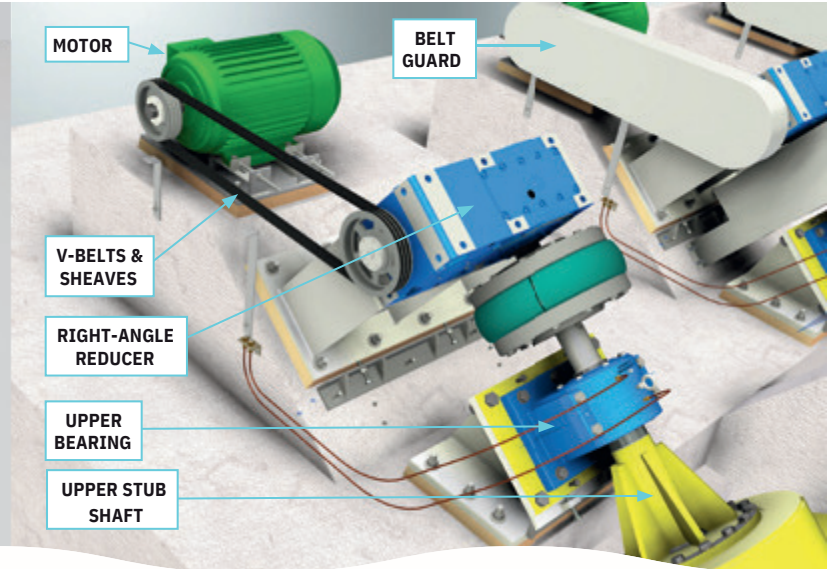

- Direct-Coupled Design** – All the base-mounted drives can be direct-coupled. Direct-coupled drive designs are available in lieu of connecting the motor to the input shaft of the speed reducer via V-belts and sheaves. They limit the selection of the pump speed since speed reducers are only offered in limited input to output speed ratios. Direct-coupled drive designs will also require either a special motor or variable frequency drive (VFD) for slowing down the screw during the grouting process for Open Screw Pumps.

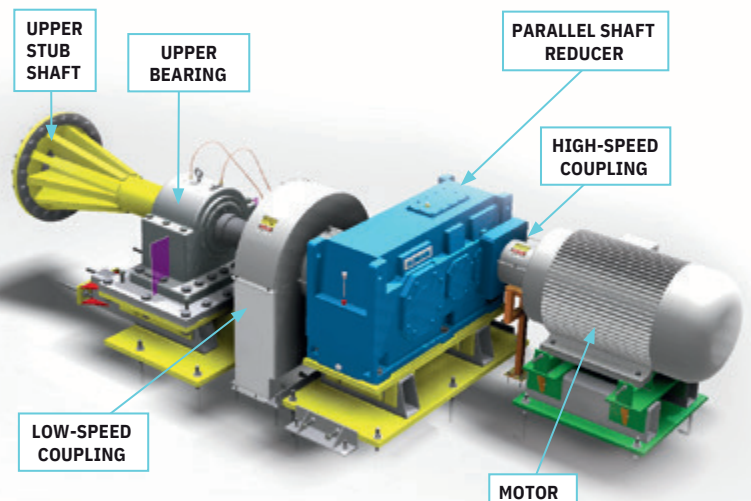

Direct-Coupled Drive Assembly

V-Belts and Sheaves In all cases, we strongly recommend that V-belt drives be used to transmit power between the motor and reducer. The reasons for this are as follows:

- Except for specially designed reducers that are cost prohibitive, reducers are furnished in a limited number of ratios. Using V-belts allows us to apply a standard reducer ratio and still provide the correct pump speed to obtain the proper pump capacity.
- It is sometimes necessary to change the speed of a pump to alter its capacity. This is an easy operation when a V-belt and sheaves drive is provided.

- The V-belts act as a shock absorber or a weak link in the drive system. This means that if a shock load should occur, the belts would normally absorb a portion of the shock and protect the reducer, which is the most expensive drive component.
- The speed at which the pump must operate to provide the required capacity has no relationship to the speed necessary for grouting the trough. With a V-belt drive, it is a simple matter of providing a set of sheaves and belts to slow the screw pump down for the grouting operation. Direct-drive designs require a special grouting motor or variable frequency drive (VFD) be provided to the contractor to grout the trough.



Fabricated Troughs



Deflection Plates



Type "S" Screw Pump Tube Vents

Screw Pump Troughs and Tubes In our standard Open Screw Pump design, grout is installed as a liner in the screw pump trough. To provide the proper gap between the screw flights and the trough, a screed rod that is tack-welded to one screw flight. The gap increases with pump diameter since screw pumps deflect under load. Mirolxtec recommends using a minimum of 3 inches of grout and can provide the suggested grout mix to the engineer and contractor. After grouting, the screed bar is removed, any latent tack weld is ground off, and the screw pump body prime paint is touched-up and finish painted.

Another option is to provide a fabricated steel or stainless steel liner. The trough liner is attached to the structural concrete and grout is pumped between the trough and the concrete to provide structural integrity. These liners are more expensive than grout, especially with the stainless steel option.

Another option is to provide a trough that is completely fabricated of carbon steel. This option can be provided to replace competitor's Type "C" Enclosed Screw Pumps that are oriented at 38 degrees for a lower installed cost.

For Open Screw Pumps, flow deflection plates are provided along the length of the pump body on the leading side to prevent liquid from slipping past the pump flights as fluid is being conveyed. Flow deflection plates are fabricated from carbon steel as a standard design with stainless steel available as an optional material.

For Type "S" Enclosed Screw Pumps the fabricated tube is provided with equally-spaced vents along the top of the structural tube to allow air to vent as the fluid is being pumped to prevent a phenomena called air-binding.

Open Screw Pump Trough and Drive Assembly Covers

Trough covers and drive assembly isolation covers are available for Open Screw Pump installations. Trough covers are normally provided for installations where odors may be of a concern or in cold northern climates to mitigate freezing. Mirolxtec trough covers can be provided and fabricated of grating, aluminum, or fiber reinforced plastic (FRP). The trough covers can also be designed to be connected to an odor control system. For installations where the drive assembly is located inside a building, drive cover plates can be provided by Lakeside.



Odor Control

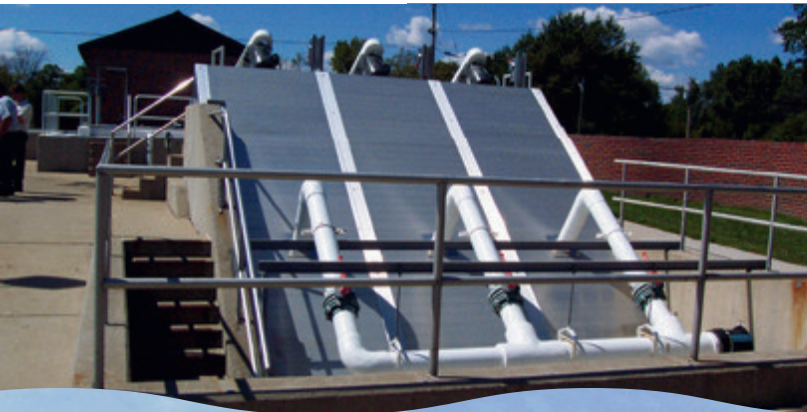

Drive Assembly Cover Plate



Trough Covers



Treatment equipment and process solutions from Mirolxtec Equipment Corporation

Mirolxtec offers a wide range of equipment and systems for virtually all stages of wastewater treatment from influent through final discharge. Each process and equipment item that we supply is manufactured with one goal: to reliably improve the quality of our water resources in the most cost-effective way. We have been doing just that since 1928.

Screw Pumps

- Open Screw Pumps
- Enclosed Screw Pumps

Raptor® Screening

- Fine Screen
- Micro Strainer
- Rotating Drum Screen
- Septage Acceptance Plant
- Septage Complete Plant Complete Plant
- Multi-Rake Bar Screen
- FalconRake™ Bar Screen
- Rotary Strainer Screen
- Wash Press

Screen and Trash Rakes

- Hydronic T Series
- Hydronic K Series
- Hydronic Multifunctional Series
- Hydronic H Series
- Catronic Series
- Monorail Series
- HY-TEC Screen
- CO-TEC Screen
- RO-TEC Screen

Grit Collection

- SpiraGrit Vortex Grit Removal System
- Aeroductor Grit Removal System
- In-Line Grit Collector
- Raptor® Grit Washer
- Grit Classifier
- H-PAC®

Clarification and Filtration

- Spiraflo Clarifier
- Spiravac Clarifier
- Full Surface Skimming

Biological Treatment

- CLR Process
- Magna Rotor Aerators & Accessories
- Sequencing Batch Reactors
- Package Treatment Plants
- Submersible Mixers & Recirculation Pumps

Hauled Waste Receiving Systems

- Raptor® Septage Acceptance Plant
- Raptor® Septage Complete Plant
- Raptor® FOG Acceptance Plant

Package Headworks Systems

- Raptor® Complete Plant

- H-PAC®

Biological Treatment Systems

- CLR Process
- Package Treatment Plants
- Sequencing Batch Reactors
- SharpBNR™ Process Control



Phone : +32474050255

Email : info@mirolxtec.com

Address : Generaal Lemanstraat 55/2 2019 Antwerpen Belgium